



October 21, 2015

Invitation to Bid 16068 Fabricated Steel Module Structure  
Addendum 1

No Change, Bid shall be publically opened at, 2:00 p.m. November 3, 2015, in the Dogwood Conference Room.

Addendum 1 is issued to answer the following questions:

1. Sheet A4, det. 6 (lower right hand corner of page) calls out the exterior wall column as TS 6 x 4 x 3/8, and on Sheet A2 calls it out as TS 6 x 4 x 1/4 in det. 1, which is correct?

Answer: The structural column at Grid 3 is a TS 6 x 4 x 3/8 as indicated on sheet S4 while the non-structural column at Grid 2 may be a TS 6 x 4 x 1/4 as indicated on sheet A2.

2. Also sheet A4, det. 2, calls out top perimeter as TS 6 x 4 x 3/8 and on sheet MP1, det. 1, calls out as TS 6 x 4 x 1/4?

Answer: The reference on sheet MP1 is incorrect. RB-1 is a TS 6 x 4 x 3/8 as indicated on sheets A4 and S4.

3. In reference to door jambs, sheet A4, det. 6, calls out as TS 4 x 2 x 3/16 and det. 3, same sheet A4 calls out TS 6 x 2 x 3/16?

Answer: The door jambs on the interior walls (Grids 2 and 3) are TS 4 x 2 x 3/16 while the door jambs on the exterior wall (Grid A) are TS 6 x 2 x 3/16.

4. Sheet S3 under notes specifies to use 5' wide sheets so that the joints are centered on purlins. However, the purlins (angle 3 x 3 x 1/4) are located on 6' centers. Is it acceptable to use 6' wide sheets?

Answer: Yes, 6' wide sheets are acceptable.

5. Drawings show a double wall at the common end wall; when the units come together does there need to be two walls?

Answer: Yes, the design calls for 2 separate insulated end walls.

6. Even though the units are to be connected in the field, is the Contractor to provide all holes/tabs at columns and the angle welded to the bottom of the W12's at the common end?

Answer: Yes, see Appendix C, paragraph 6.

7. Is the back wall penetration clear opening (24 1/2 or 24)?

Answer: All openings in the back wall are 24-1/2" as indicated on details 2 and 3 of sheet MP-1.

8. Sheet 5, grids 1,3, and 5 show some sort of stud into the tube?

Answer: There is no stud in the tube. See sheet S5 Revision 1 for a corrected detail.

9. It appears the 4-each lifting eyes at the common end walls will conflict with each other as drawn. Can they be rotated 90 degrees? This would position them knifed into the tube column the 6" way, thus leaving a 1/4" of the 6 1/2" pad eye exposed for welding. The way depicted at present, knifed in the 4" way leaves a 1 1/4" exposed each side of the tube column thus they would butt up against each other leaving a 2 1/2" gap between the modules.

Answer: The detail has been corrected to show the 6-1/2" pad eye running parallel to Grid lines 1, 3, and 5 (the 6" dimension of the tube). See sheet S11 Revision 1 for a corrected detail.

10. In looking the module over and the specifications regarding painting and priming it states specifically that the module is to be primed and painted in a warm facility. This brings to forefront the size of the module. Specifically the width of 17'. There are few doors that can handle this width. In addition, transporting a structure of this width is quite costly with the advent of DOT regulations. Is there a particular reason that the module has to be this width? Is there a reason we cannot pare it down to 16'? It appears that all of your interior setbacks can be satisfied for NFPA at the lessor width.

Answer: The module will serve as a prime power plant and the dimensional layout is designed to provide appropriate access for maintenance and operations.

11. On Sheet A4, details 1 & 2 denote the interior elevations as being 11'6". Detail 3 shows the control room interior as being 10' in height. The measurement given does seem to indicate that the control room measurement is to the bottom of the 6"x4" header. Even so, assuming that the header accounts for 6", there is a 1' disparity. Is this an accurate measurement?

Answer: The control room height is 11'-6" to the bottom of the 6x4 header. See sheet A4 Revision 1 for a corrected detail.

Important, acknowledge receipt of addenda, Appendix C Bid Schedule, Page 30, item 16. "Acknowledge all addenda" of the original invitation to bid document.

Thank you for your interest in our requirements.

Althea S. Clapp  
Senior Contracting Officer  
[aclapp@aidea.org](mailto:aclapp@aidea.org)

REVISIONS	REV. DATE	DESCRIPTION
1	10/20/15	REVISION 1

VERIFY SCALES  
 0 1"  
 THIS BAR REPRESENTS ONE INCH ON ORIGINAL DRAWING

DATE: 09/23/15  
 DRAWN BY: RW  
 CHECKED BY: RW  
 JOB NUMBER:

DRAWING TITLE:  
 MODULE BUILDING  
 INTERIOR ELEVATIONS  
 DOOR & WINDOW DETAILS

A4

SHEET OF

NOTE: LOCATIONS, QUANTITY AND DETAILS OF ALL MECHANICAL WALL PENETRATIONS SHOWN ON SHEET MP1.

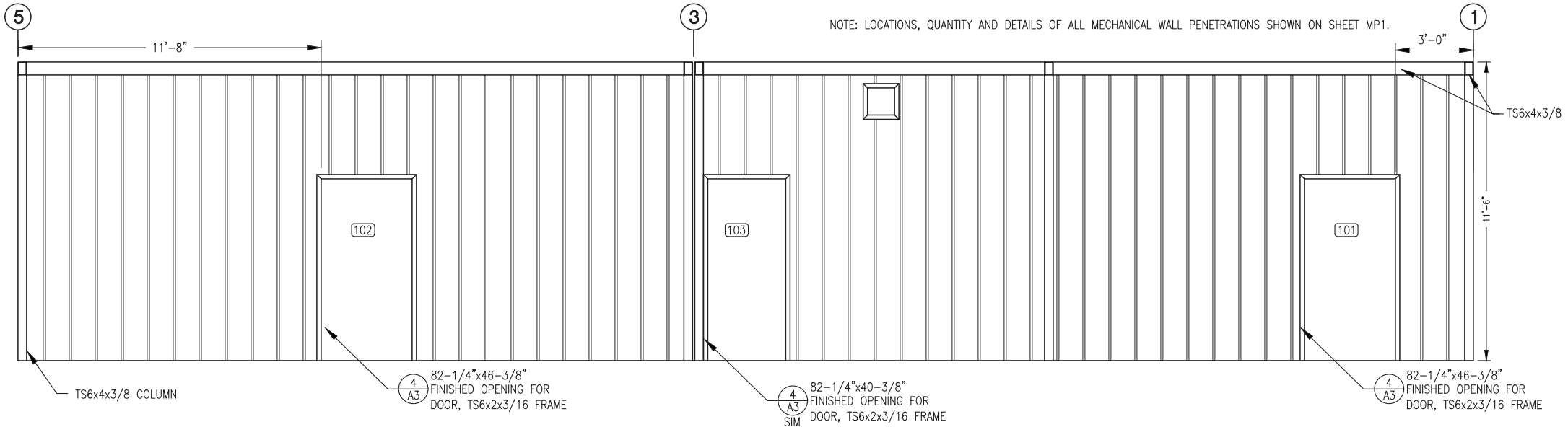

1 FRONT WALL INTERIOR ELEVATION  
 3/8"=1'-0"

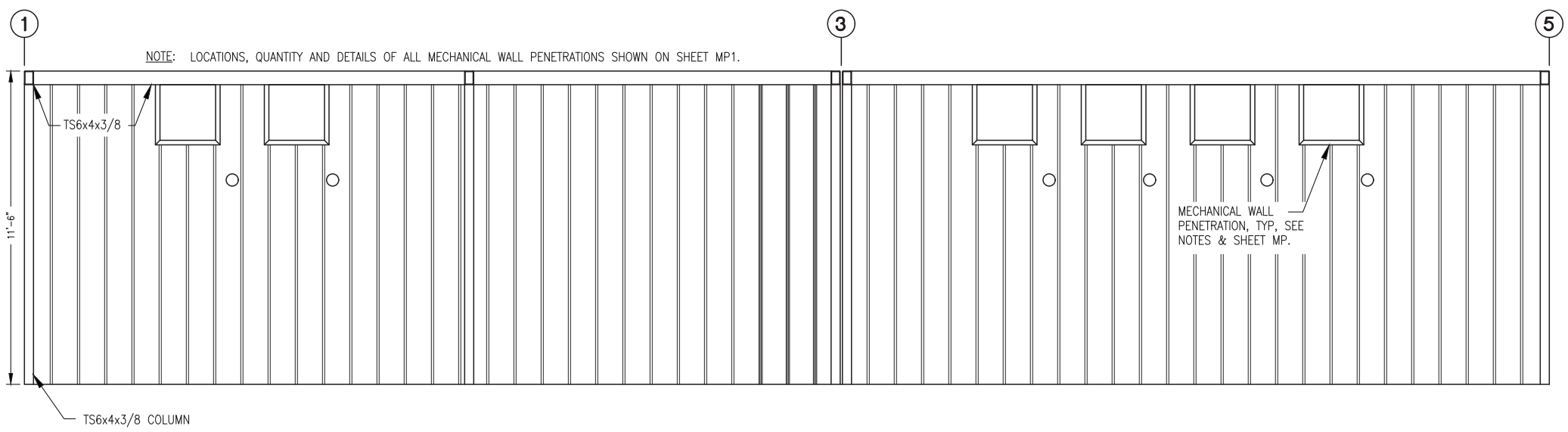

2 PARTIAL GENERATOR ROOM BACK WALL INTERIOR ELEVATION  
 3/8"=1'-0"

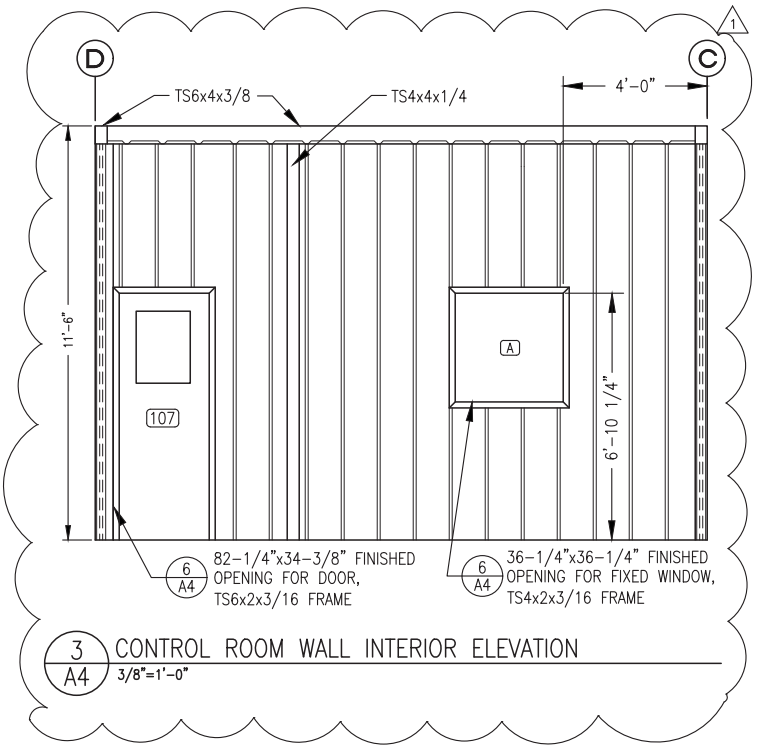

3 CONTROL ROOM WALL INTERIOR ELEVATION  
 3/8"=1'-0"

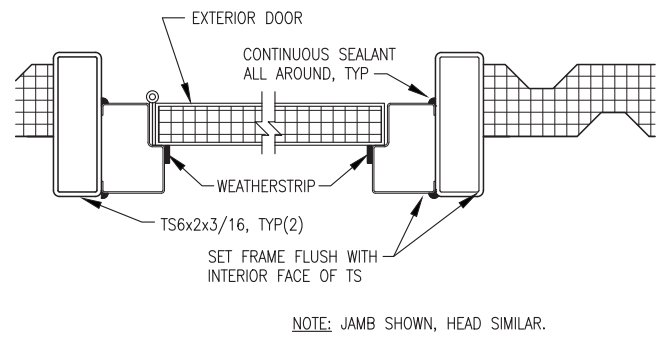

4 TYPICAL EXTERIOR DOOR JAMB/HEAD  
 3"=1'-0"

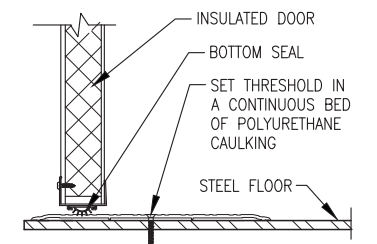

5 TYPICAL DOOR THRESHOLD  
 NO SCALE

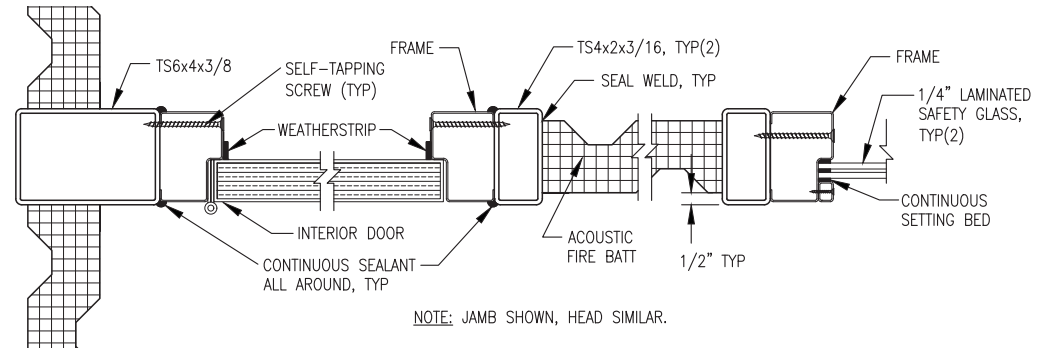

6 INTERIOR DOOR AND WINDOW JAMB/HEAD  
 3"=1'-0"

STATE OF ALASKA, AIDEA/AEA  
RURAL POWER SYSTEM UPGRADE  
KIPNUK LIGHT PLANT  
KIPNUK, ALASKA

CONSTRUCTION  
DOCUMENTS

REV. NO.	DATE	DESCRIPTION
1	10/20/15	REVISION 1

VERIFY SCALES  
0 1"  
THIS BAR REPRESENTS  
ONE INCH ON ORIGINAL  
DRAWING

DATE: 09/23/15  
DRAWN BY: DM  
CHECKED BY: DG  
JOB NUMBER:

DRAWING TITLE:  
MODULE CONNECTION  
DETAILS

S5

SHEET OF

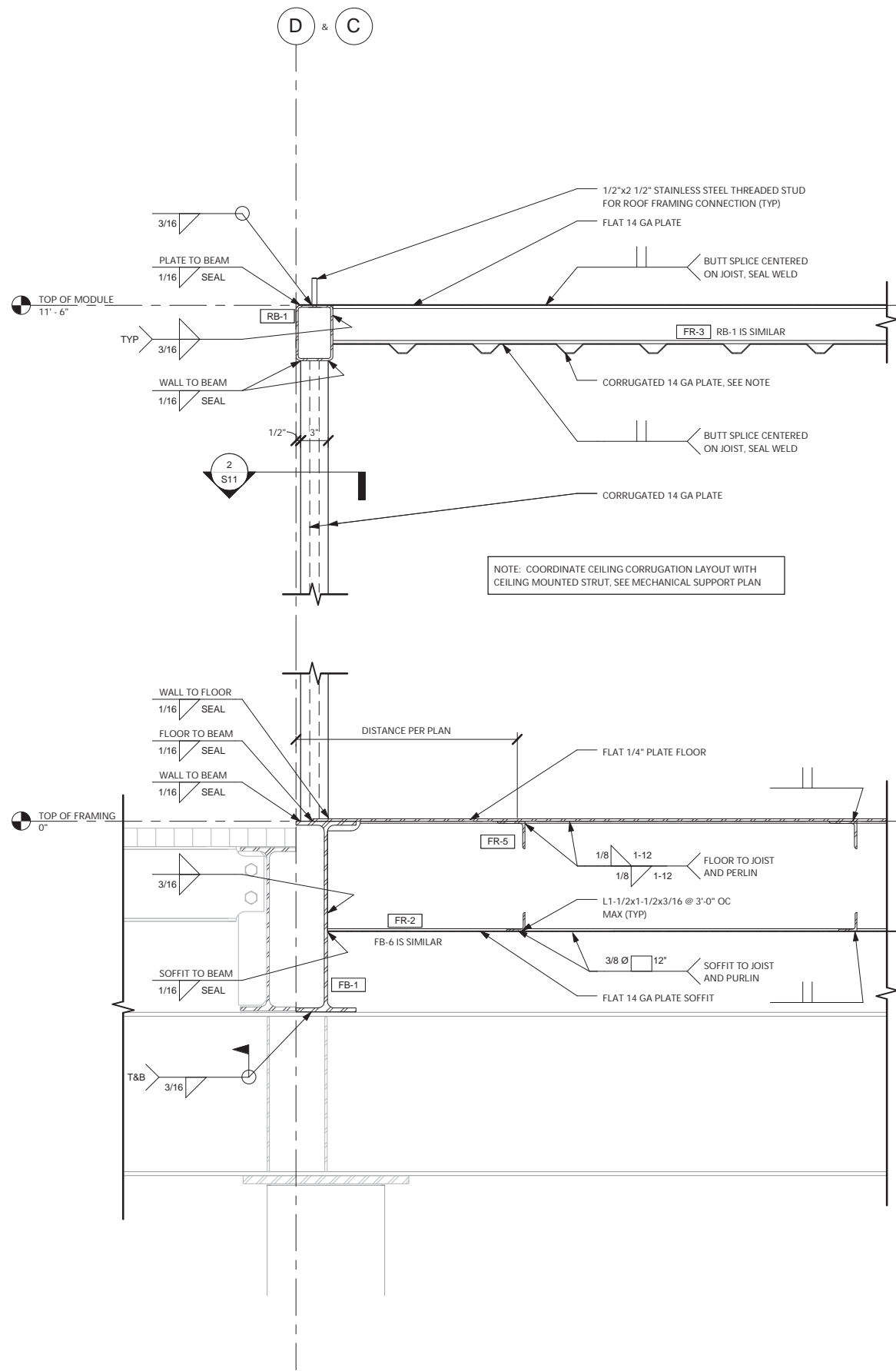

3 Section 3  
S5 1 1/2" = 1'-0"

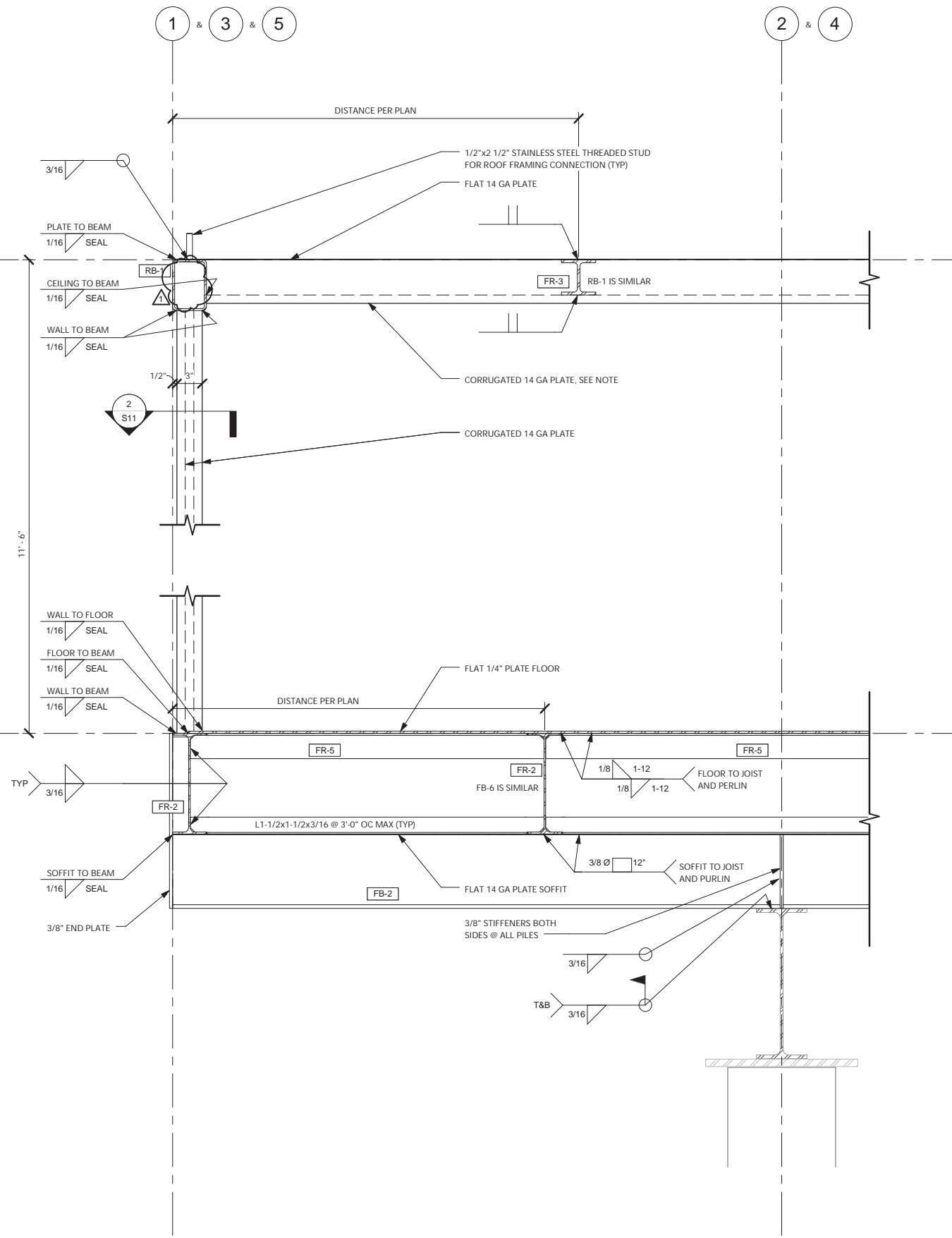

4 Section 4  
S5 1 1/2" = 1'-0"

REV. NO.	DATE	DESCRIPTION
1	10/20/15	REVISION 1

VERIFY SCALES  
0 1" = 1"  
THIS BAR REPRESENTS ONE INCH ON ORIGINAL DRAWING

DATE: 09/23/15  
DRAWN BY: DM  
CHECKED BY: DG  
JOB NUMBER:

DRAWING TITLE:  
MODULE DETAILS

S11

SHEET OF

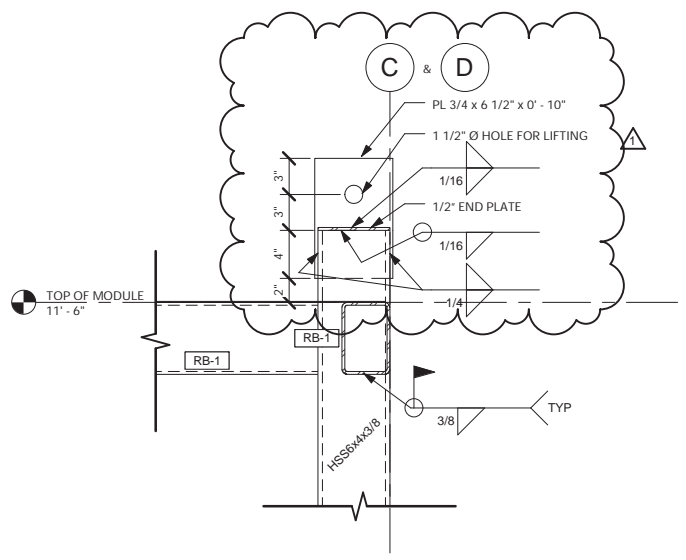

1 LIFTING EYE & COLUMN CONNECTION  
S11 1 1/2" = 1'-0"

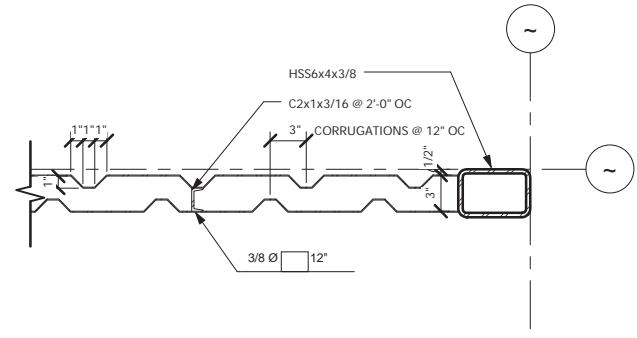

2 EXTERIOR WALL PLAN  
S11 1 1/2" = 1'-0"

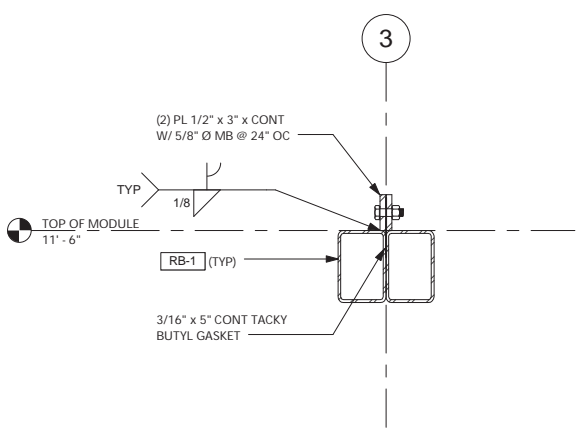

3 MODULE CONNECTION @ BEAMS  
S11 1 1/2" = 1'-0"

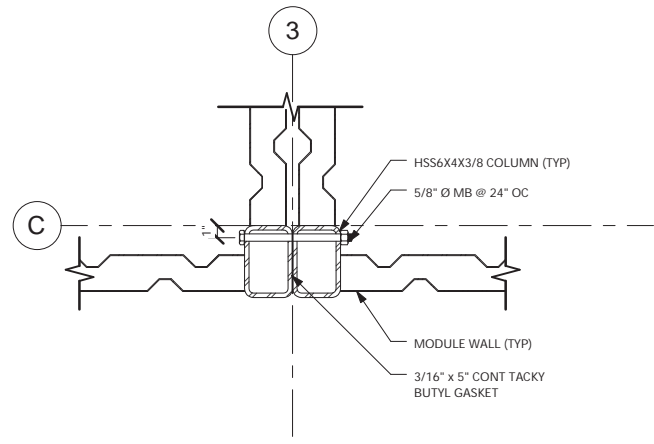

4 MODULE CONNECTION @ COLUMNS  
S11 1 1/2" = 1'-0"

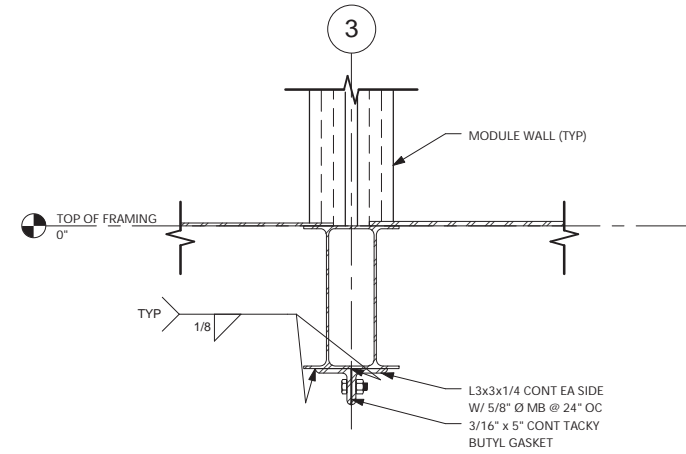

5 MODULE CONNECTION @ FLOOR  
S11 1 1/2" = 1'-0"